

REVISION HISTORY			
REV	DESCRIPTION	DATE	APPROVED
00	PRELIMINARY ISSUE	12/15/2011	J.M

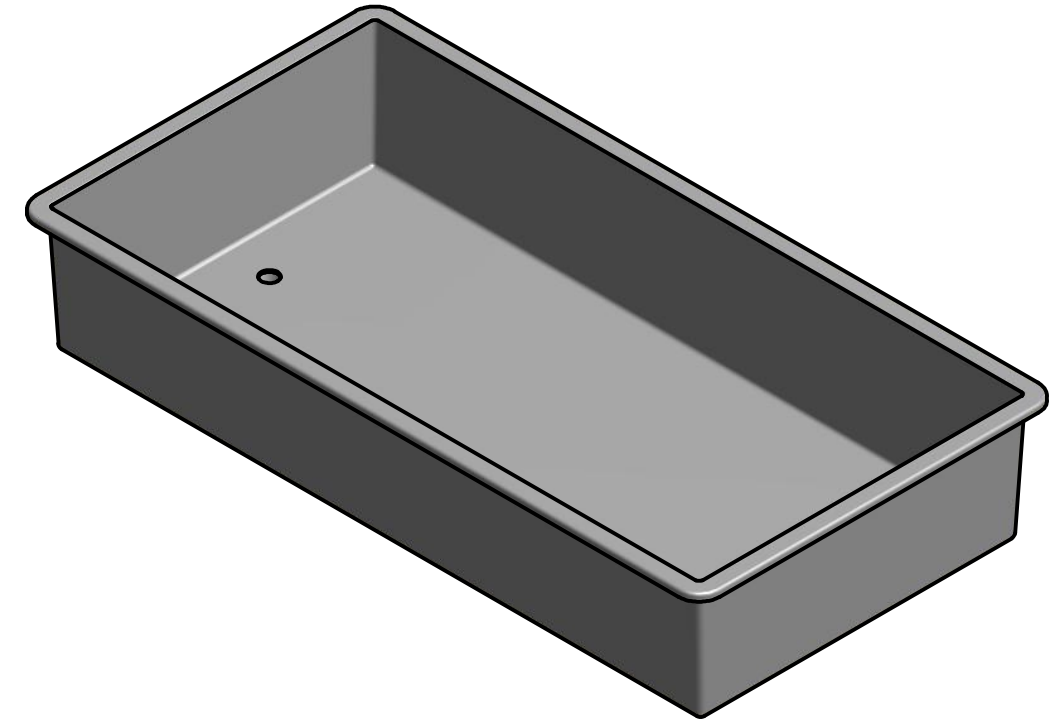

NOTES

- 1) MANUFACTURED USING HIGH GRADE RESIN, COMBINED WITH CHOPPED STRAND AND WOVEN GLASS.
- 2) AVAILABLE WITH ISOPHTHALIC PROTECTIVE GELCOATS.
- 3) CAPACITY: 1322 (L), 349 (US GAL), 291 (IMP GAL)
- 4) TYPE OF FITTING, SIZE AND LOCATION IF ANY, TO BE DETERMINED BY CUSTOMER.

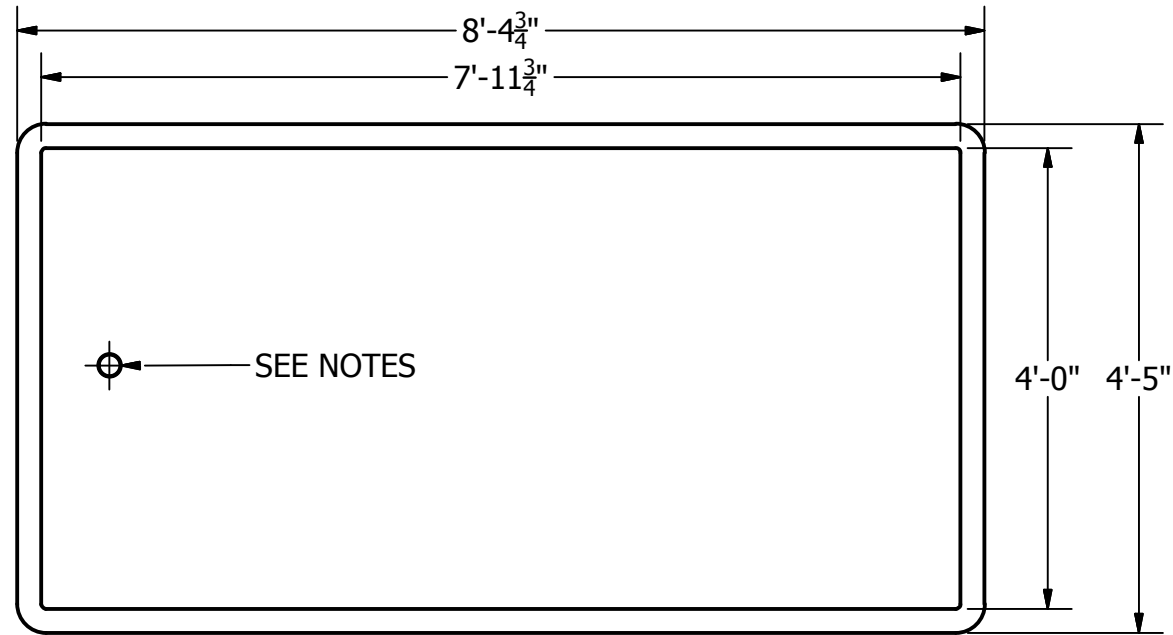
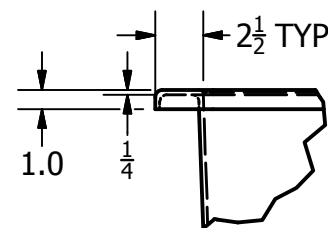
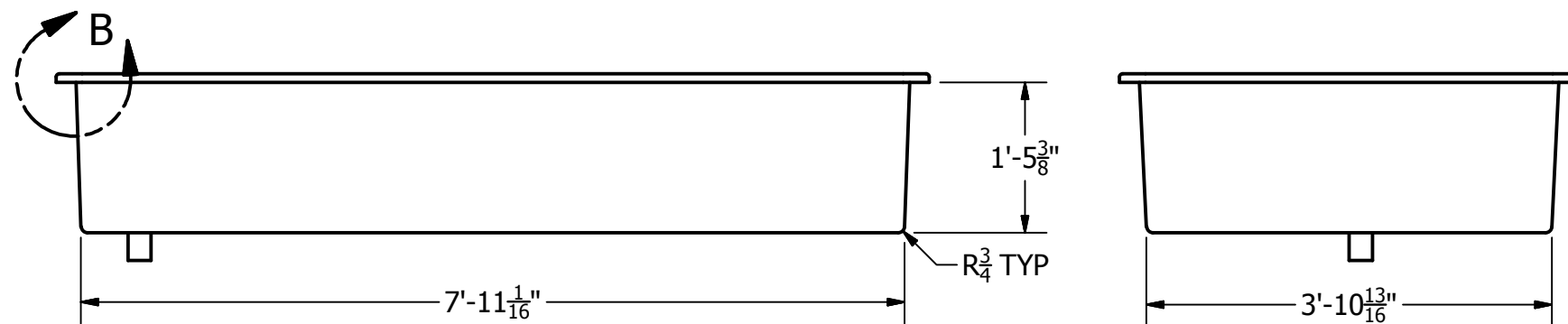

**OVERHANGING LIP
DETAIL B
SCALE 1 / 10**

PO #:				
CUSTOMER:				
 DURA-TECH INDUSTRIAL & MARINE LIMITED 206 Ross Road Dartmouth, Nova Scotia B2Z 1B4 Telephone (902) 462-8265 Fax (902) 462-8235	DRAWING TITLE: LT265-8	DESIGNED BY:		
	SCALE: 1/20	DRAWN BY: J.M		
	DATE: 11/30/2011	REVISIONS: ○ ○	REVIEWED BY:	
	DWG NO.: LT265-8		APPROVED BY:	
		PROJECT NO.:	SHEET NO.: 1 OF 1	