

REVISION HISTORY			
REV	PART NUMBER	DESCRIPTION	DATE
00	RT 23-2 OT	PRELIMINARY ISSUE	10/06/2011

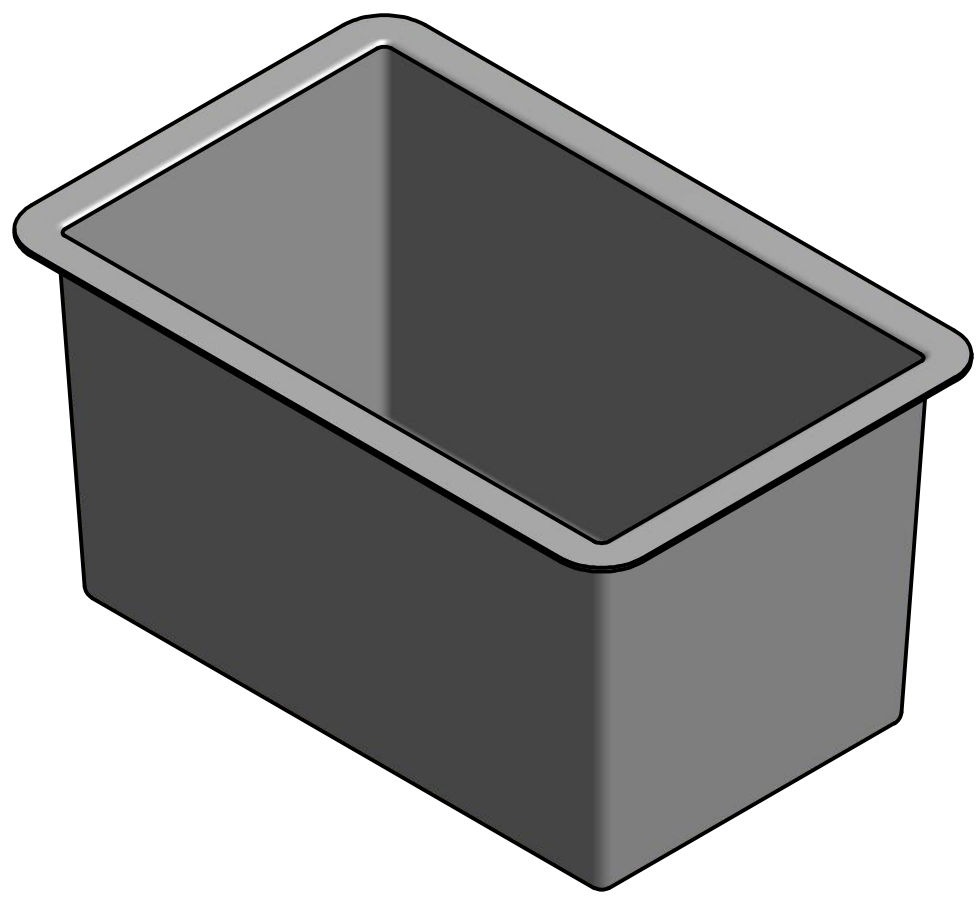
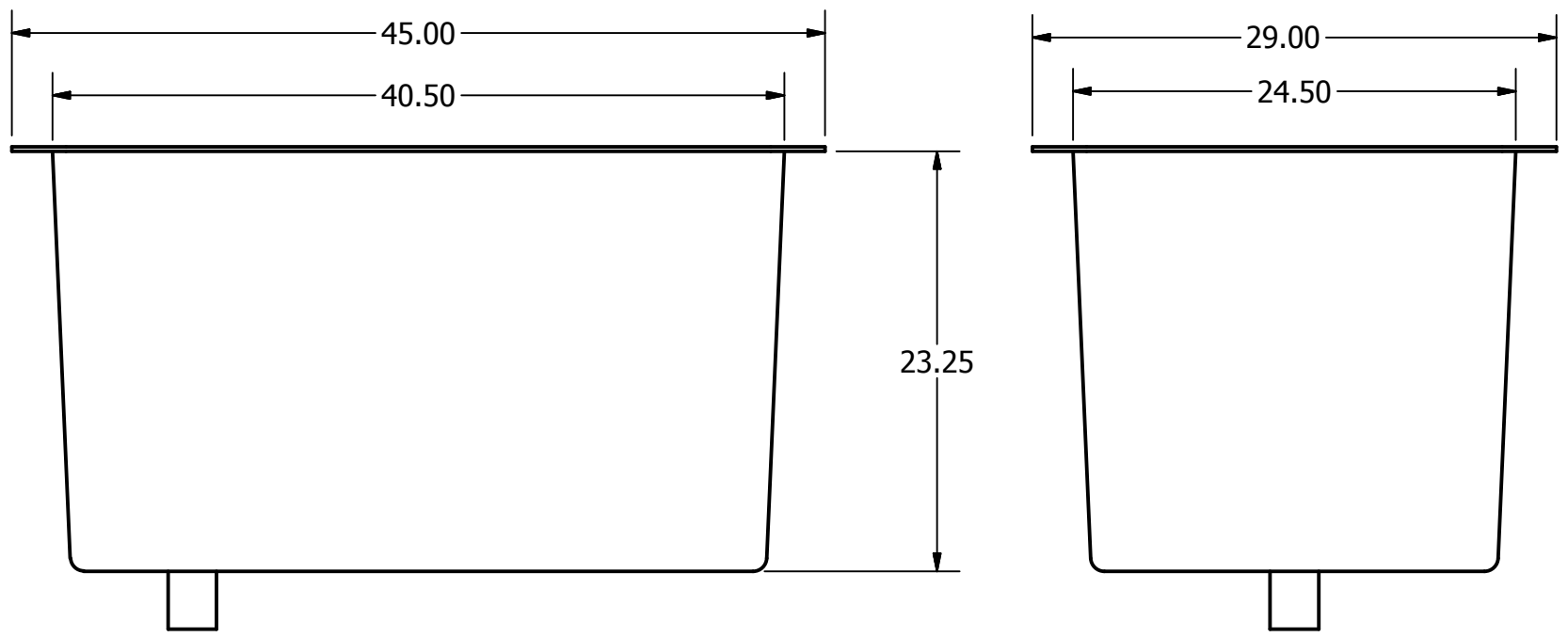
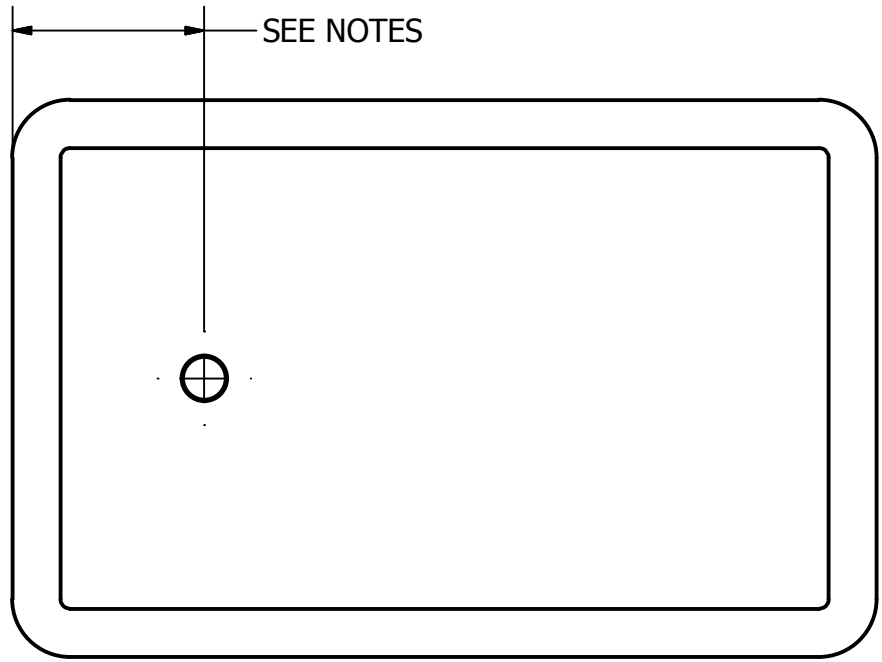

NOTES:
 MODEL: RT 23-2 OT
 CAPACITY: 338 (L); 89 US GAL; 74 IMP GAL
 FLANGE: 2.5"
 DRAIN FITTING - TYPE AND POSITION
 TO BE DETERMINED BY CUSTOMER

PO #:		DRAWING TITLE:		DESIGNED BY:	
CUSTOMER:		SCALE: 1 / 10		DRAWN BY:	
 DURA-TECH INDUSTRIAL & MARINE LIMITED 206 Ross Road Dartmouth, Nova Scotia B2Z 1B4 Telephone (902) 462-8265 Fax (902) 462-8235		DATE: 10/6/2011		REVIEWED BY:	
		REVISIONS:		APPROVED BY:	
DWG NO.: RT 23-2 OT		PROJECT NO.:		SHEET NO.: 1 OF 1	